



Residential Hybrid System Installation and Operation Manual

FOR INDOOR APPLICATIONS ONLY

RHS199100.....119 gallon, 199,000 BTU

The Residential Hybrid System is assembled with multiple and separately certified components consisting of:

- RUC98i Residential Tankless Water Heater
- Storage Tank
- Controller

**READ ALL OF THE INSTRUCTIONS THOROUGHLY BEFORE
INSTALLING OR OPERATING THIS SYSTEM.**

**(This manual is a supplement to the RUC98i Installation and
Operation Manual)**

This manual provides information on the installation, operation, and maintenance of the water heater. For proper operation and safety, it is important to follow the instructions and adhere to the safety precautions.

A licensed professional must install the water heater according to the exact instructions in this manual.

The consumer must read the entire manual to properly operate the water heater and to have regular maintenance performed.

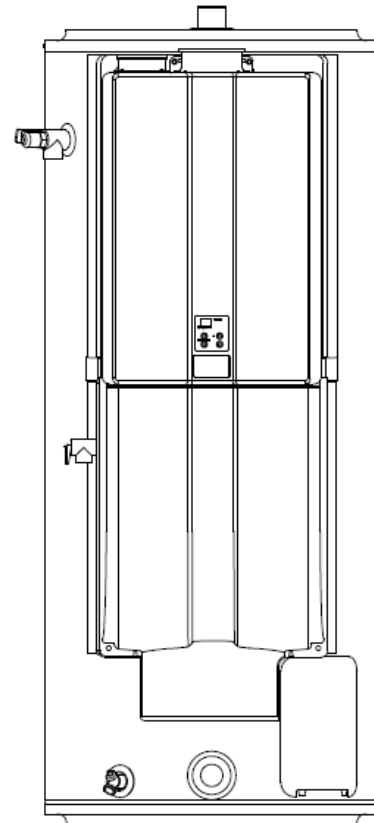

⚠ WARNING

If the information in these instructions is not followed exactly, a fire or explosion may result causing property damage, personal injury, or death.

- Do not store or use gasoline or other flammable vapors and liquids in the vicinity of this or any other appliance.
- **WHAT TO DO IF YOU SMELL GAS**
 - Do not try to light any appliance.
 - Do not touch any electrical switch; do not use any phone in your building.
 - Immediately call your gas supplier from a neighbor's phone. Follow the gas supplier's instructions.
 - If you cannot reach your gas supplier, call the fire department.
- Installation and service must be performed by a qualified installer, service agency or the gas supplier.

Table of Contents

Safety Behaviors and Practices for the Consumer and Installer	3	Storage Tank Maintenance	23
Installation Instructions (for the licensed professional)	4	Replacement Parts	24
Installer Qualifications	4	Service / Maintenance Log	25
Type of Installation	4	Warranty	26
Installation Steps.....	4	Notes	29
General Instructions.....	4		
Prepare for Installation	5		
Determine Installation Location	6		
Direct Vent Terminal Clearances	7		
Venting Guidelines.....	9		
Typical Installations.....	10		
Installation of Plumbing.....	11		
Piping Diagram for Basic Installations.....	12		
Piping Diagram for Multiple Unit Installations	13		
Installation of Gas Supply	15		
Connect Electricity	16		
System Controller	17		
Condensate	18		
Final Checklist	20		
Technical Data	21		
Specifications	21		
Dimensions	22		

NOTICE:

Rinnai sometimes shares customer contact information with businesses that we believe provide products or services that may be useful to you. By providing this information, you agree that we can share your contact information for this purpose. If you prefer not to have your information shared with these businesses, please contact customer service and ask not to have your information shared. We will however, continue to contact you with information relevant to the product(s) you registered and/or your account with us.

If you have any questions or feel that the manual is incomplete contact Rinnai at 1-800-621-9419.

Important Safety Information

Safety Definitions



This is the safety alert symbol. This symbol alerts you to potential hazards that can kill or hurt you and others.



Indicates an imminently hazardous situation which, if not avoided, will result in personal injury or death.



Indicates a potentially hazardous situation which, if not avoided, could result in personal injury or death.



Indicates a potentially hazardous situation which, if not avoided, could result in minor or moderate injury. It may also be used to alert against unsafe practices.

Safety Behaviors and Practices for the Consumer and Installer

WARNING

- Before operating, smell all around the appliance area for gas. Be sure to smell next to the floor because some gas is heavier than air and will settle on the floor.
- Keep the area around the appliance clear and free from combustible materials, gasoline, and other flammable vapors and liquids.
- Combustible construction refers to adjacent walls and ceiling and should not be confused with combustible or flammable products and materials. Combustible and/or flammable products and materials should never be stored in the vicinity of this or any gas appliance.
- Always check the water temperature before entering a shower or bath.
- To protect yourself from harm, before performing maintenance:
 - ◇ Turn off the electrical power supply by unplugging the power cord or by turning off the electricity at the circuit breaker. (The temperature controller does not control the electrical power.)
 - ◇ Turn off the gas at the manual gas valve, usually located immediately below the water heater.
 - ◇ Turn off the incoming water supply. This can be done at the isolation valve immediately below the water heater or by turning off the water supply to the building.
- Use only your hand to push in or turn the gas control knob. Never use tools. If the knob will not push in or turn by hand, do not try to repair it; call a licensed professional. Force or attempted repair may result in a fire or explosion.
- Do not use this appliance if any part has been under water. Immediately call a licensed professional to inspect the appliance and to replace any part of the control system and any gas control which has been under water.
- Do not use substitute materials. Use only parts certified for the appliance.
- Should overheating occur or the gas supply fail to shut off, turn off the manual gas control valve to the appliance.
- Do not adjust the DIP switch unless specifically instructed to do so.
- Do not use an extension cord or an adapter plug with this appliance.
- Any alteration to the appliance or its controls can be dangerous and will void the warranty.
- Proper venting is required for the safe operation of this appliance.

CAUTION

- BURN HAZARD. Hot exhaust and vent may cause serious burns. Keep away from the water heater unit. Keep small children and animals away from the unit.
- Hot water outlet pipes leaving the unit can be hot to touch.

WARNING

California law requires the following notice to be provided:

California Proposition 65:

This product contains chemicals known to the state of California to cause cancer, birth defects, or other reproductive harm.

INSTALLATION INSTRUCTIONS

(for the licensed professional)

Installer Qualifications

A licensed professional must install the appliance, inspect it, and leak test it before use. The warranty will be voided due to any improper installation.

The installer should have skills such as:

- Gas sizing
- Connecting gas lines, water lines, valves, and electricity
- Knowledge of applicable national, state, and local codes
- Installing venting through a wall or roof
- Training in installation of Rinnai water heaters (training can be accessed online at www.trainingevents.rinnai.us)

Type of Installation

For installation in Residential applications only.

Installation Steps

Prepare for Installation	5
Determine Installation Location.....	6
Venting Guidelines	9
Installation of Plumbing	11
Checklist for Plumbing	14
Installation of Gas Supply.....	15
Connect Electricity	16
Checklist for Gas and Electricity.....	17
System Controller.....	17
Condensate	18
Final Checklist.....	20

General Instructions

DO NOT

- Do not install the Residential Hybrid System outdoors.
- Do not install the appliance in an area where water leakage of the unit or connections will result in damage to the area adjacent to the appliance or to lower floors of the structure. When such locations cannot be avoided, it is recommended that a suitable drain pan, adequately drained, be installed under the appliance. The pan must not restrict combustion air flow.

- Do not obstruct the flow of combustion and ventilation air. Combustion air shall not be supplied from occupied spaces.
- Do not use this appliance in an application such as a pool or spa heater that uses chemically treated water . (This appliance is suitable for filling large or whirlpool spa tubs with potable water.)
- Do not use substitute parts that are not authorized for this appliance.

MUST DO

- The installation must conform with local codes or, in the absence of local codes, with the *National Fuel Gas Code, ANSI Z223.1/NFPA 54*, or the *Natural Gas and Propane Installation Code, CSA B149.1*.
- The appliance, when installed, must be electrically grounded in accordance with local codes or, in the absence of local codes, with the *National Electrical Code, ANSI/NFPA 70*, or the *Canadian Electrical Code, CSA C22.1*.
- The appliance and its appliance main gas valve must be disconnected from the gas supply piping system during any pressure testing of that system at test pressures in excess of 1/2 psi (3.5 kPa) (13.84 in W.C.).
- The appliance must be isolated from the gas supply piping system by closing its individual manual shutoff valve during any pressure testing of the gas supply piping system at test pressures equal to or less than 1/2 psi (3.5 kPa) (13.84 in W.C.).
- You must follow the installation instructions and those in *Care and Maintenance* for adequate combustion air intake and exhaust.

General Instructions (Continued)

INFORMATION

- If a water heater is installed in a closed water supply system, such as one having a backflow preventer in the cold water supply line, means shall be provided to control thermal expansion. Contact the water supplier or local plumbing inspector on how to control thermal expansion.
- Should overheating occur or the gas supply fail to shut off, turn off the manual gas control valve to the appliance.
- Keep the air intake location free of chemicals, such as chlorine or bleach, that produce fumes. These fumes can damage components and reduce the life of your appliance.

EARTHQUAKE STRAPPING

NOTICE

Product installed in the state of California must be braced, anchored, or otherwise secured to avoid motion or falling during an earthquake. Contact the California Office of the State Architect located at 1102 Q Street, Suite 5100, Sacramento, CA 95811 for instructions.

1. Loosen screws along the perimeter of the plastic enclosures
2. Remove plastic enclosures
3. Position straps around the Demand Duo tank per the requirements of California Office of the State Architect. **DO NOT POSITION STRAPS OVER PIPE, FITTINGS or WIRE.**
4. Replace the plastic enclosures. (*Modification of the plastic enclosures may be necessary to fit the enclosures over the earthquake straps.*)
5. Replace the screws around the perimeter of the plastic enclosures.

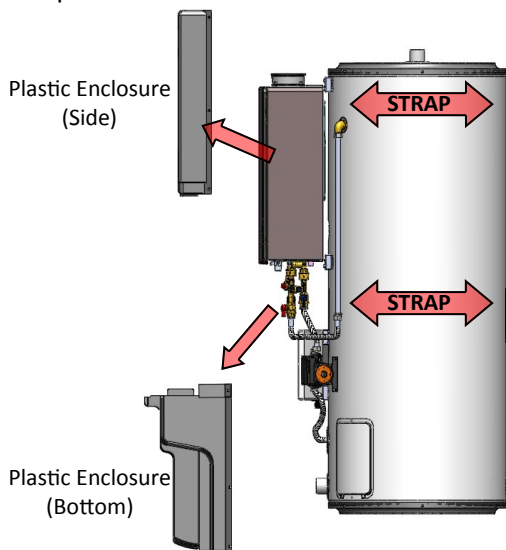

Prepare for Installation

Parts included

- Residential Hybrid System
- Temperature and Pressure Relief Valve (Tank)
- Pressure Relief Valve (Preinstalled on Tankless)

Tools needed

- Pipe wrenches (2)
- Adjustable pliers
- Screwdrivers (2)
- Wire cutters
- Gloves
- Safety glasses
- Level

Tools that might be needed

- Hammer drill with concrete bits
- Saw
- Threading machine with heads and oiler
- Core drill with diamond head
- Torch set
- Copper tubing cutter
- Steel pipe cutter

Materials needed

- Soap or gas leak detector solution
- Approved venting
- Teflon tape (recommended) or pipe compound
- Pipe insulation

Materials that may be needed

- Heat tape
- Electrical wire and conduit per local code
- PVC glue/cement
- 5/8" ID PVC flexible tubing
- 2 conductor 22 AWG wire for controller
- Single gang electrical box
- Wire nuts
- Unions and drain valves
- Drain Pan
- Earthquake Strap

Determine Installation Location

You must ensure that clearances will be met and that the vent length will be within required limits. Consider the installation environment, water quality, and need for freeze protection. Requirements for the gas line, water lines, electrical connection, and condensate disposal can be found in their respective installation sections of this manual.

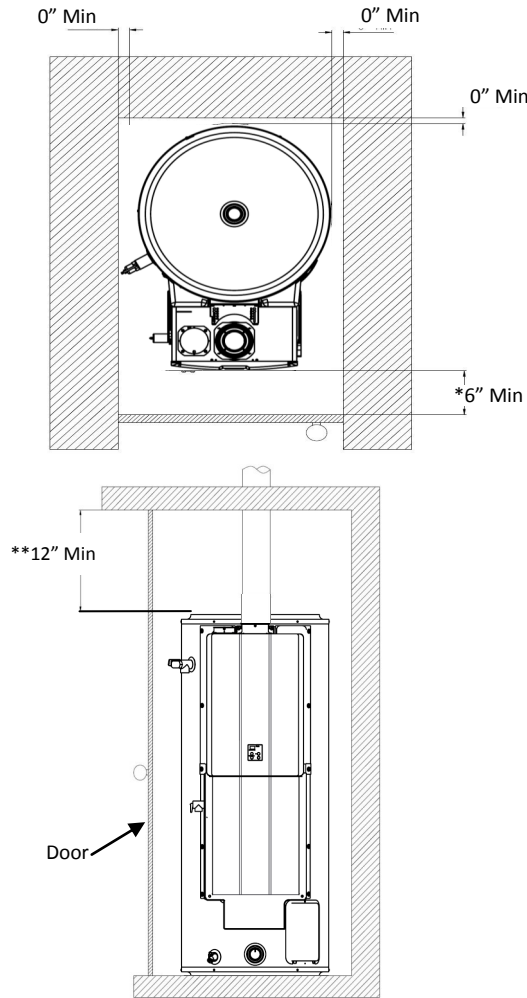

Minimum Clearances

The minimum clearances from both combustibles and non-combustibles construction is:

- 0 inches from the sides
- 0 inches from the back
- 12 inches from the top
- 6 inches from the front
- 0 inches from vent components and condensate drain line.

**The clearance for servicing is 24 inches in front of the water heater.*

***The clearance for servicing the anode rods is 54 inches from the top of the water heater.*

Determine Installation Location (Continued)

System Transport

- Choose the right hand truck to support the weight and size of the water heater. Refer to the "Specifications" section in this manual for specific weights and dimensions.
- Use proper lifting techniques to load the water heater onto the hand truck.
- Position the water heater onto the hand truck so the weight is evenly balanced and the tank is touching the rails of the hand truck.
- Secure the water heater to the hand truck by:
 - ◆ Positioning **STRAP A** around the tankless unit as illustrated below (**do not overtighten**).
 - ◆ Positioning **STRAP B** around the base of the tank below the lower enclosure.

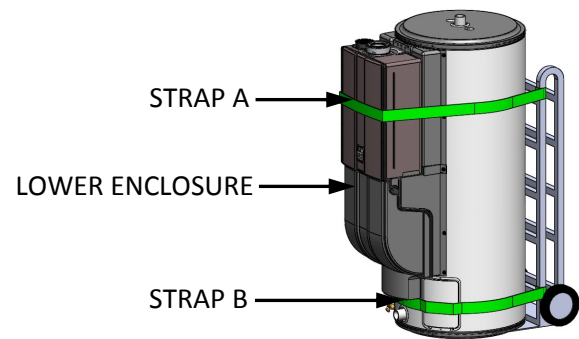

Checklist to Determine Installation Location

- The water heater is not exposed to corrosive compounds in the air.
- The water heater location complies with the clearances.
- For indoor models, the planned venting will not exceed the maximum length for the number of elbows used.
- The planned venting termination/air intake location meets the clearances.
- Indoor air is not being used for combustion.
- The water supply does not contain chemicals or exceed total hardness that will damage the heat exchanger.
- The installation must conform with local codes or, in the absence of local codes, with the *National Fuel Gas Code, ANSI Z223.1/NFPA 54*, or the *Natural Gas and Propane Installation Code, CSA B149.1*.
- Leave the entire manual taped to the water heater, or give the entire manual directly to the consumer.**

Direct Vent Terminal Clearances

A vent termination must be installed to bring in combustion air and expel exhaust to the outside.

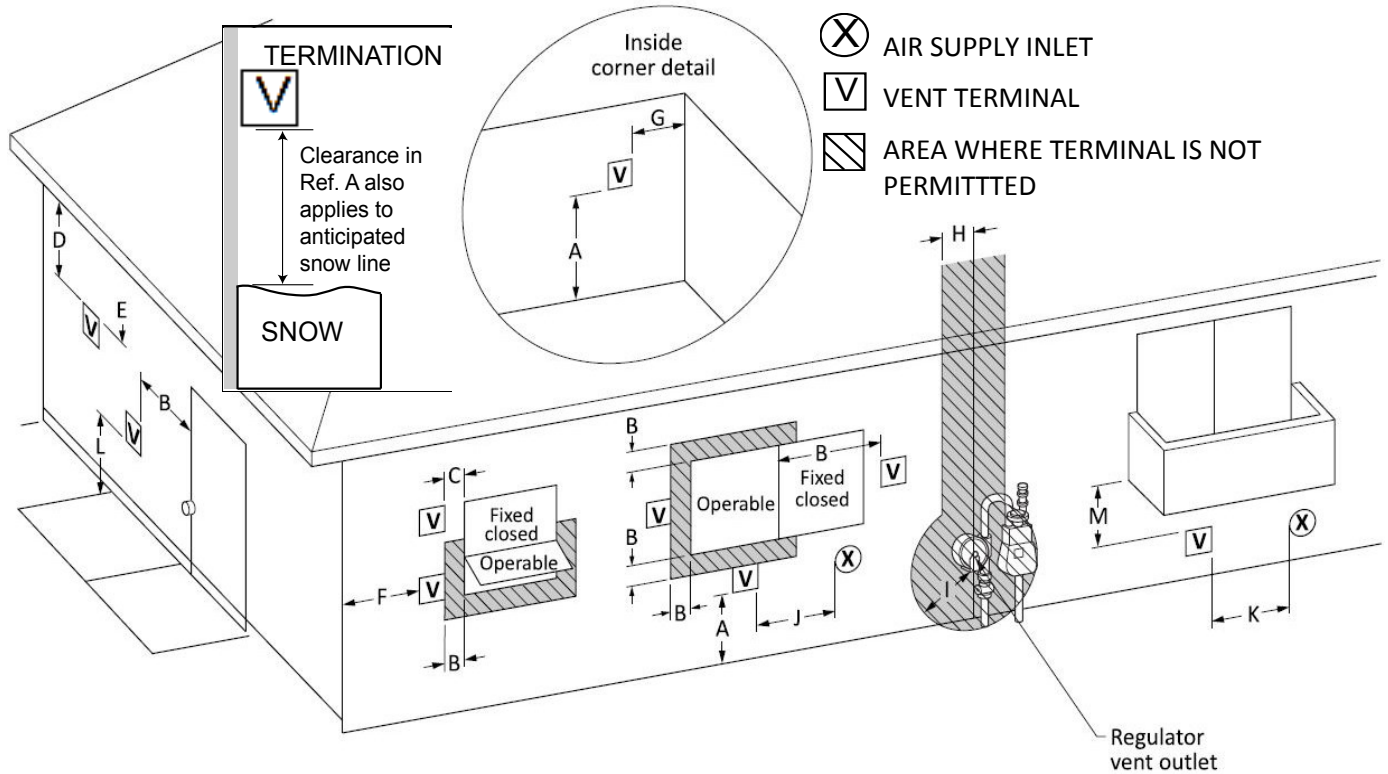

Ref	Description	Canadian Installations	US Installations
A	Clearance above grade, veranda, porch, deck, or balcony	12 inches (30 cm)	12 inches (30 cm)
B	Clearance to window or door that may be opened	36 inches (91 cm)	12 inches (30 cm)
C	Clearance to permanently closed window	*	*
D	Vertical clearance to ventilated soffit, located above the terminal within a horizontal distance of 2 feet (61 cm) from the center line of the terminal	*	*
E	Clearance to unventilated soffit	*	*
F	Clearance to outside corner	*	*
G	Clearance to inside corner	*	*
H	Clearance to each side of center line extended above meter/regulator assembly	*	*
I	Clearance to service regulator vent outlet	Above a regulator within 3 ft (91cm) horizontally of the vertical center line of the regulator vent outlet to a maximum vertical distance of 15 ft (4.5 m)	*
J	Clearance to nonmechanical air supply inlet to building or the combustion air inlet to any other appliance	36 inches (91 cm)	12 inches (30 cm)
K	Clearance to a mechanical air supply inlet	6 feet (1.83 m)	3 feet (91 cm) above if within 10 feet (3 m) horizontally
L	Clearance above paved sidewalk or paved driveway located on public property	7 feet (2.13 m) ①	*
M	Clearance under veranda, porch, deck, or balcony	12 inches (30 cm) ②	*

[1] A vent shall not terminate directly above a sidewalk or paved driveway that is located between two single family dwellings and serves both dwellings.

[2] Permitted only if veranda, porch, deck, or balcony is fully open on a minimum of two sides beneath the floor.

* For clearances not specified in *ANSI Z223.1/NFPA 54*, clearances are in accordance with local installation codes and the requirements of the gas supplier.

Clearance to opposite wall is 24 inches (60 cm).

REFER TO THE RUC98i MANUAL FOR SPECIFIC DETAILS ON:

- Approved Vent Manufacturers and Terminations
- Termination Clearances
- Maximum Vent Length
- Flue Installation with Concentric Venting
- Common Vent Application
- Twin Pipe PVC/CPVC Vent Installation
- Consumer Operation Guidelines for the Safe Operation of your Water Heater
- How to use the RUC98i Temperature Controller
- RUC98i Diagnostic Codes
- RUC98i Required Maintenance (*Draining of the tankless water heater requires the lower enclosure to be removed. Refer to the “Installation of Gas Supply” section in this manual for steps on removing the lower enclosure.*)
- RUC98i Replacement Parts

Venting Guidelines

DO NOT

- Do not use cellular core PVC/CPVC.
- Do not use Radel, ABS, or galvanized material to vent this appliance.
- Do not cover non-metallic vent pipe and fittings with thermal insulation.
- Do not combine vent components from different manufacturers.
- Vent diameter must not be reduced.
- Do not connect the venting system with an existing vent or chimney.
- Do not common vent with the vent pipe of any other manufacturer's water heater or appliance. Rinnai water heaters can only be common vented using a Rinnai certified common vent system.

MUST DO

- This water heater is a direct vent water heater and therefore is certified and listed with the vent system. You must use vent components that are certified and listed with the water heater model.
- The vent system must vent directly to the outside of the building and use outside air for combustion, except for Residential Hybrid System Applications.
- Avoid dips or sags in horizontal vent runs by installing supports per the vent manufacturer's instructions.
- Support horizontal vent runs every four feet and all vertical vent runs every six feet or in accordance with local codes.
- Venting should be as direct as possible with a minimum number of pipe fittings.
- Vent connections must be firmly pressed together so that the gaskets form an air tight seal.
- The vent piece connected to the water heater must be secured with one self-tapping screw.

INFORMATION

- Refer to the instructions of the vent system manufacturer for component assembly instructions.
- If the vent system is to be enclosed, it is suggested that the design of the enclosure shall permit inspection of the vent system. The design of such enclosure shall be deemed acceptable by the installer or the local inspector.

NOTICE

If it becomes necessary to access an enclosed vent system for service or repairs, Rinnai is not responsible for any costs or difficulties in accessing the vent system. The warranty does not cover obtaining access to a vent system in an enclosed environment.

Typical Installations

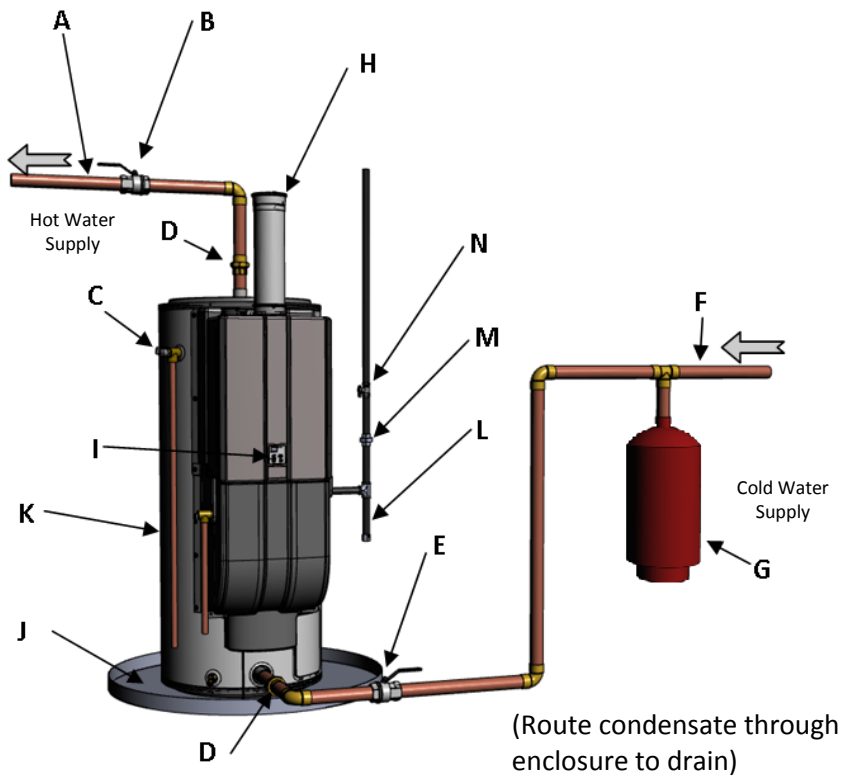

A	Hot Water Outlet	*
B	Hot Water Outlet Valve	*
C	Temperature-Pressure Relief Valve	
D	Cold and Hot Unions	*
E	Cold Water Supply Valve	*
F	Cold Water Supply	*
G	Thermal Expansion Tank	*
H	Vent pipe (concentric shown for illustration purposes, see venting section for other options)	*
I	Operation Unit / Temperature Control	
J	Drain Pan	*
K	Temperature-Pressure Relief Valve Discharge Pipe (do not cap, plug, or reduce)	*
L	Drip Leg (Sediment Trap)	*
M	Gas Union	*
N	Gas Control Valve	
O	Thermostatic Mixing Valve	*
P	Non-Tempered Return Line	*
Q	Non-Tempered Supply Line	*

Mixing Valve Installation

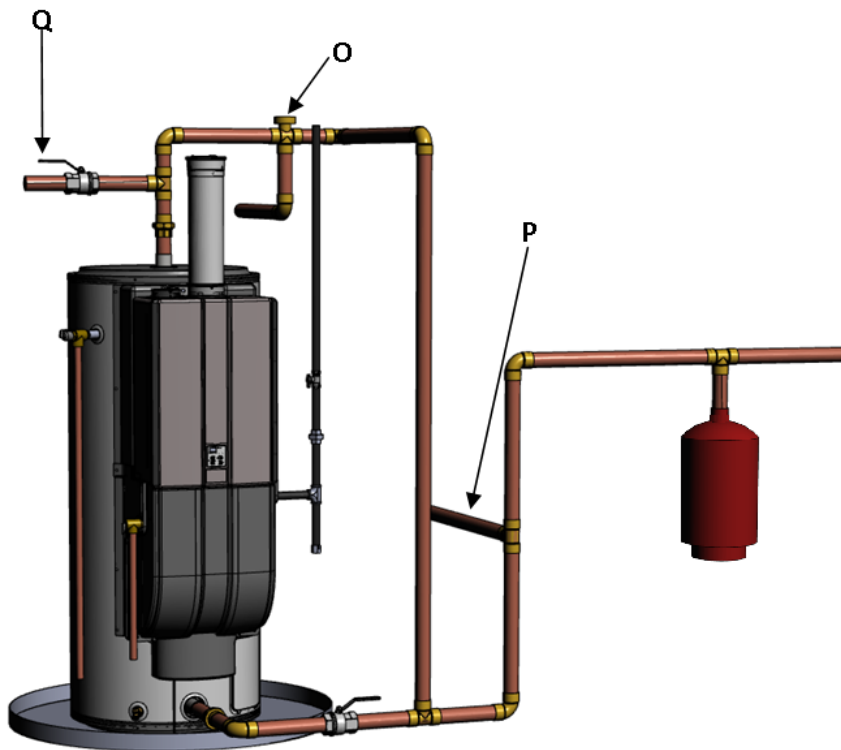

* Field Supplied

Installation of Plumbing

Pressure Relief Valve Requirements

An approved pressure relief valve (preinstalled) is required by the *American National Standard (ANSI Z21.10.3)* for all water heating systems and shall be accessible for servicing.

DO NOT

- Do not plug the relief valve and do not install any reducing fittings or other restrictions in the relief line. The relief line should allow for complete drainage of the valve and the line.
- Do not place any other type valve or shutoff device between the relief valve and the water heater.

MUST DO

- The relief valve must comply with the standard for *Relief Valves and Automatic Gas Shutoff Devices for Hot Water Supply Systems ANSI Z21.22* and /or the standard *Temperature, Pressure, Temperature and Pressure Relief Valves and Vacuum Relief Valves, CAN1-4.4*.
- The pressure relief valve must be rated up to 150 psi and to at least the maximum BTU/hr of the appliance.
- The discharge from the pressure relief valve should be piped to the ground or into a drain system per local codes.
- The pressure relief valve must be manually operated once a year to check for correct operation.
- The relief valve should be added to the hot water outlet line and near the hot water outlet according to the manufacturer's instructions. DO NOT place any other type valve or shut off device between the relief valve and the water heater.

WARNING

Water discharged from the pressure relief valve could cause severe burns instantly or death from scalds.

INFORMATION

If a relief valve discharges periodically, this may be due to thermal expansion in a closed water supply system. Contact the water supplier or local plumbing inspector on how to correct this situation. Do not plug the relief valve.

Temperature-Pressure Relief Valve Requirements

Install the Temperature-Pressure Relief (T&P) Valve according to these instructions.

The tank portion of this system is provided with a combination temperature-pressure relief valve. For safe operation of the water heater, the relief valve(s) must not be removed from its designated point of installation or plugged.

An approved Temperature-Pressure Relief Valve is required by the *American National Standard (ANSI Z21.10.3)* for all water heating systems, and shall be accessible for servicing.

DO NOT

- Do not plug the T&P valve and do not install any reducing fittings or other restrictions in the relief line. The relief line should allow for complete drainage of the T&P valve and the line.
- Do not place any other type valve or shut off device between the relief valve and the water heater.
- Do not pipe temperature-pressure relief valve, pressure relief valve, and/or condensate drain together into a common pipe.

MUST DO

- The T&P valve must comply with the standard for *Relief Valves and Automatic Gas Shutoff Devices for Hot Water Supply Systems ANSI Z21.22* and /or the standard *Temperature, Pressure, Temperature and Pressure Relief Valves and Vacuum Relief Valves, CAN1-4.4*.
- The T&P valve must be rated up to 150 psi and to at least the maximum BTU/hr of the appliance.
- The discharge from the T&P Valve should be piped to the ground or into a drain system to prevent exposure or possible burn hazards to humans or other plant or animal life. Follow local codes. Water discharged from the relief valve could cause severe burns instantly, scalds, or death.
- The Temperature-Pressure Relief Valve must be manually operated once a year to check for correct operation.

Piping Diagram for Multiple Unit Installations

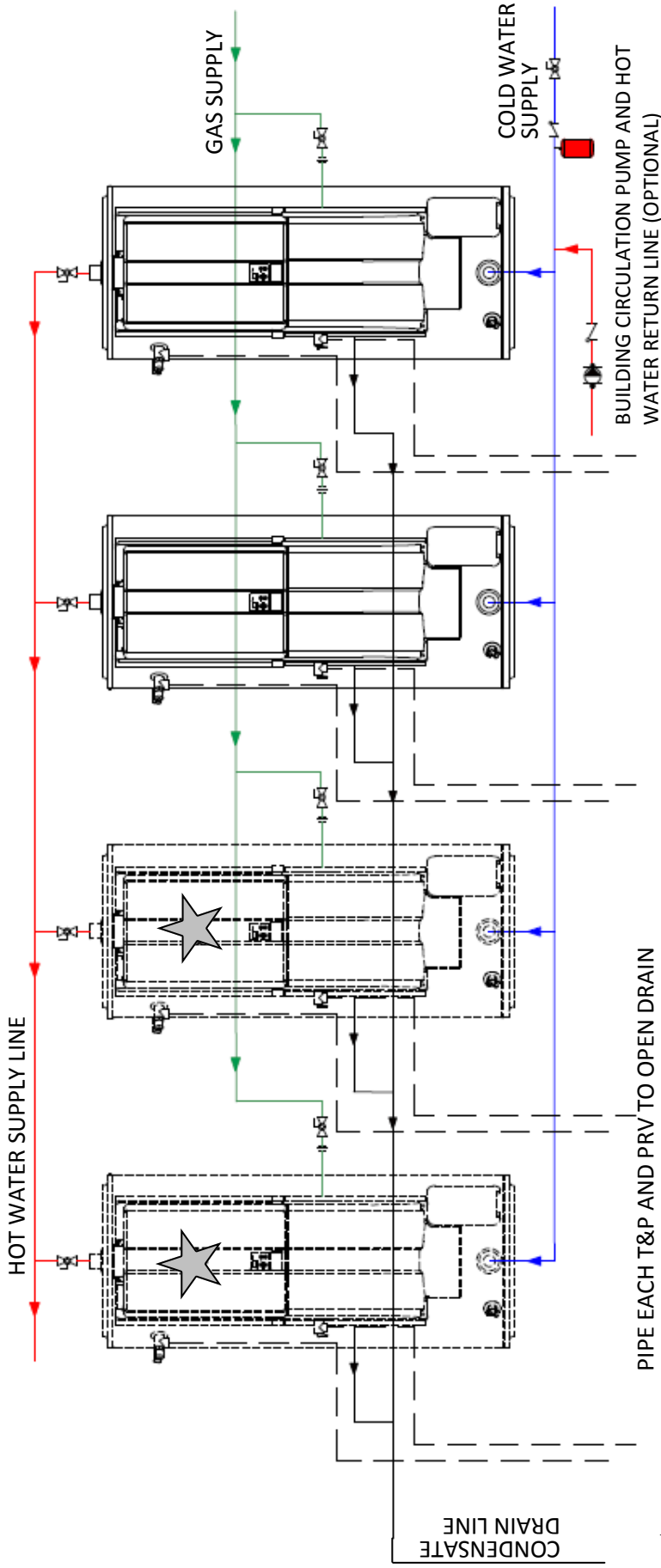

Additional units can be installed as illustrated.

Notes:

- Installation must conform to applicable code and all requirements listed in the installation manual. Balancing valves, equivalent piping, pressure gages, and temperature gages are to be used as necessary to ensure proper flow between units.
- Condensate piping shall be CPVC or PVC material and shall not be smaller than the drain connection on the appliance.
- Components of the condensate drainage shall be CPVC or PVC material. All components shall be selected for the pressure and temperature rating of the installation.
- Where the drain pipes from more than one unit are manifolded together for condensate drainage, the pipe or tubing shall be sized in accordance with an approved method as dictated by local codes.
- Condensate must be disposed of according to local codes.

Connect Water Heater to Water Supply

Water connections to the Residential Hybrid System should follow all state and local plumbing codes.

If this is a standard installation, refer to the Piping Diagram for basic installation.

1. Use of this layout should provide a trouble-free installation for the life of the water heater. Before making the plumbing connections, locate the **COLD** water inlet and the **HOT** water outlet.
 - The **COLD** water inlet is a 2" MNPT fitting on the lower portion of the tank below the tankless unit.
 - The **HOT** water outlet is a 2" MNPT fitting located at the top of the tank. Install a shut-off valve close to the water heater in the cold water line. It is recommended that unions be installed in the cold and hot water lines so that the water heater can be easily disconnected, if servicing is required.
2. When assembling the hot and cold piping, use a good food grade pipe joint compound, and ensure all fittings are tight. It is imperative that open flame is not applied to the inlet and outlet fittings, as heat will damage or destroy the plastic lined fittings. **This will result in premature failure of the fittings, which is not covered by the warranty.**

Filling the System

DO NOT OPERATE THIS WATER HEATER UNLESS IT IS COMPLETELY FULL OF WATER. To prevent damage to the water heater, all air must be relieved from the system and a hot water fixture must be flowing water before the water heater is plugged in and turned on. To ensure safe and effective operation of the water heater, use the following filling procedure. To fill the water heater:

1. Ensure the drain valve located at the bottom of the tank is closed.
2. Open the nearest hot water fixture in the plumbing system.
3. Open the cold water supply valve to the water heater.
4. Keep the hot water fixture open until the tank is filled and constant flow is obtained at the fixture.
5. Check water heater connections and plumbing system for damage or leaks. Repair if needed.

Checklist for Plumbing

- Ensure that hot and cold water lines are not crossed to the unit and are leak free.
- Ensure that a pressure relief valve is installed with a rating that exceeds the BTU input of the water heater model. Refer to the rating plate on the side of the water heater for BTU input.
- Clean the inlet water filter by closing the cold and hot water inlet isolation (shut-off) valves. Put a bucket under the filter at the bottom of the water heater to catch any water that is contained inside the unit. Unscrew the water filter. Rinse the filter to remove any debris. Install the filter and open the isolation valves.
- Check for proper water pressure to the water heater. Minimum water pressure is 50 psi. Rinnai recommends 60-80 psi for maximum performance.
- Ensure any issues regarding water quality have been properly addressed.

NOTICE

DO NOT OPERATE THIS WATER HEATER UNLESS IT IS COMPLETELY FULL OF WATER

Installation of Gas Supply

! WARNING

1. If you are not knowledgeable or qualified to install gas lines or connections, then contact a licensed professional to install the gas supply.
2. Turn off 120v power supply.
3. Turn off the gas.
4. Gas is flammable. Do not smoke or provide other ignition sources while working with gas.
5. Do not turn on the water heater or gas until all fumes are gone.

General Instructions

In order to access the gas connections, remove the plastic rivet screws that attach the lower enclosure to the assembly. Proceed to then remove the lower enclosure.

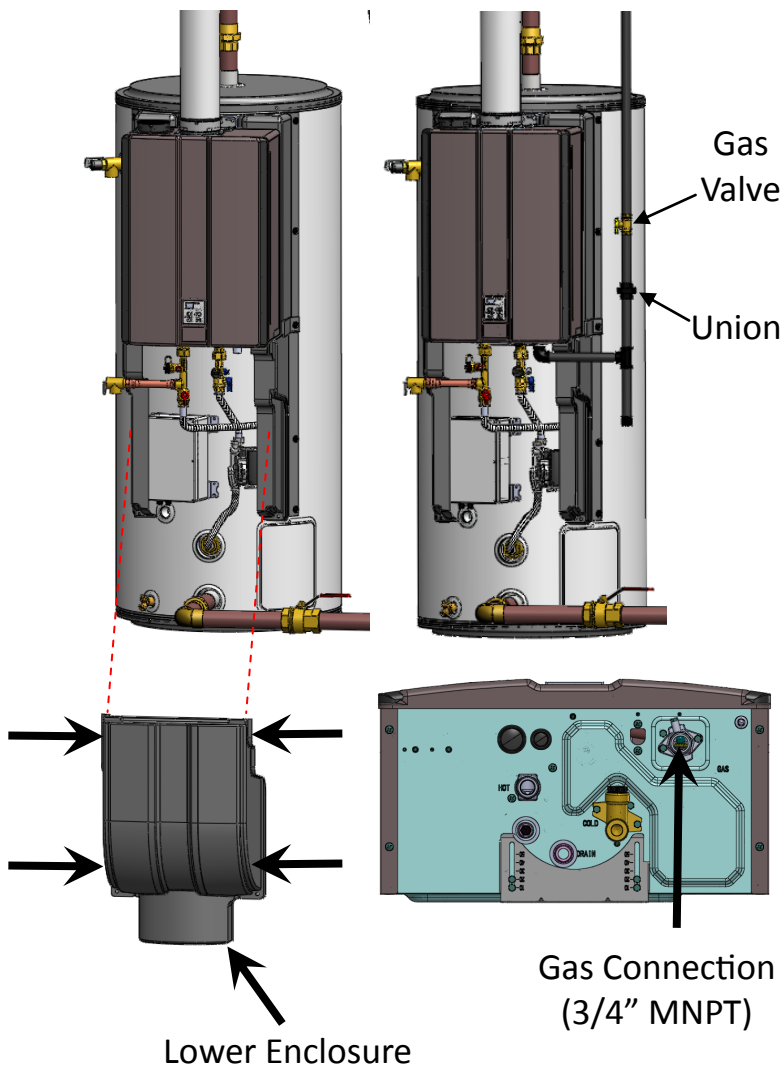

REFER TO THE RUC98i MANUAL FOR SPECIFIC DETAILS ON SIZING THE GAS PIPE.

MUST DO

- A manual gas valve must be placed in the gas supply line to the water heater. Install a union between the gas valve and the appliance for future servicing or unit removal.
- Check the type of gas and the gas inlet pressure before connecting the water heater. If the water heater is not of the gas type that the building is supplied with, DO NOT connect the water heater. Contact the dealer for the proper unit to match the gas type.
- Check the gas supply pressure immediately upstream at a location provided by the gas company. Supplied gas pressure must be within the limits shown in the Specifications section with all gas appliances operating.
- Before placing the appliance in operation all joints including the heater must be checked for gas tightness by means of leak detector solution, soap and water, or an equivalent nonflammable solution, as applicable. (Since some leak test solutions, including soap and water, may cause corrosion or stress cracking, the piping shall be rinsed with water after testing, unless it has been determined that the leak test solution is non-corrosive.)
- Use approved connectors to connect the unit to the gas line. Purge the gas line of any debris before connection to the water heater.
- Any compound used on the threaded joint of the gas piping shall be a type which resists the action of liquefied petroleum gas (propane / LPG).
- The gas supply line shall be gas tight, sized, and so installed as to provide a supply of gas sufficient to meet the maximum demand of the heater and all other gas consuming appliances at the location without loss of pressure.
- Always check all gas pipe connections and fittings for leaks before operating the water heater. Use soapy water on all fitting and visually inspect for bubble formation. Rinse off soapy water and wipe dry.

Connect Electricity

⚠ WARNING

Do not use an extension cord or an adapter plug with this appliance.

The water heating system must be electrically grounded in accordance with local codes and ordinances or, in the absence of local codes, in accordance with the National Electrical Code, ANSI/NFPA No. 70.

The tankless water heater is equipped with a three-prong (grounding) plug for your protection against shock hazard and should be plugged directly into the three-prong receptacle located at the bottom of the controller.

Do not rely on the gas or water piping to ground the water heater. A terminal block inside the controller should be used for the grounding connection.

The water heater requires 120 VAC, 60 Hz power from a properly grounded circuit.

The wiring diagram is located on the Technical Sheet attached to the inside of the front cover.

REFER TO THE RUC98i MANUAL FOR :

- High Altitude Adjustment
- Vent Length Adjustment
- Temperature Controller Installation

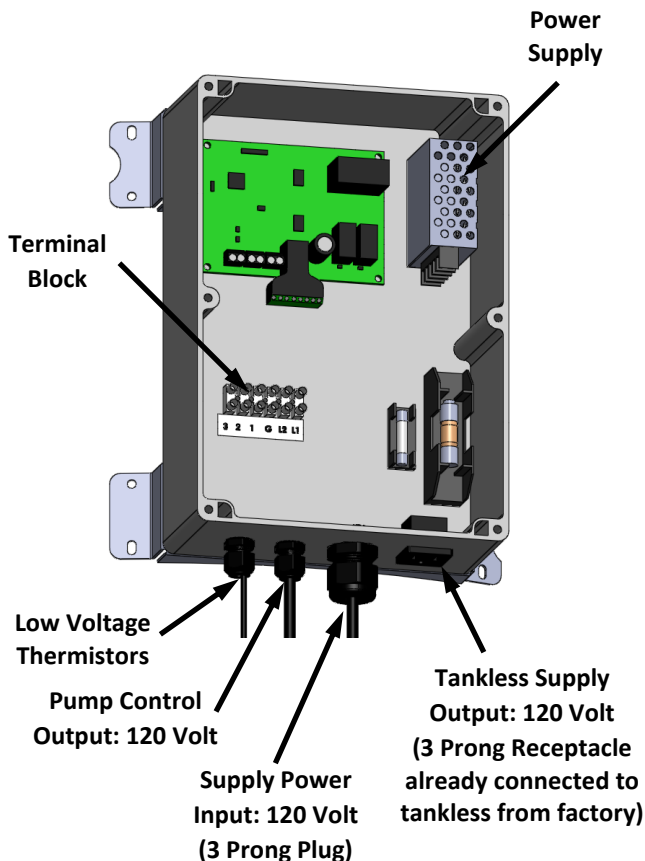
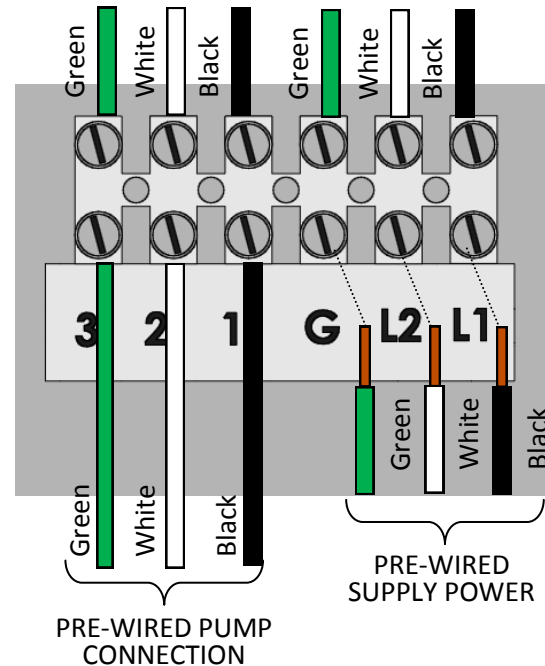

⚠ ATTENTION

DO NOT connect power to the Residential hybrid system prior to completing installation and the system has been filled with water.

Do not rely on the gas or water piping to ground the water heater. A terminal block inside the controller should be used for the grounding connection.

The water heater requires 120 VAC, 60 Hz power from a properly grounded circuit.

The wiring diagram is located on the Technical Sheet attached to the inside of the front cover.

SYSTEM CONTROLLER

The system controller maintains communication between the tank and tankless to effectively control the tank temperature based on the selected temperature on the tankless unit.

By reading the tank temperature (J22) and tankless outlet temperature (J2), the *System Controller* will energize (120V) the pump when the tank temperature drops. When the tank temperature returns to the selected set temperature the *System Controller* will de-energize the pump and remain in standby until the tank temperature drops again.

ATTENTION

When power is supplied, the System Controller will maintain pump operation. If system is not in use for an extended period of time, Disconnect power from the system.

Checklist for Gas and Electricity

- A manual gas control valve is placed in the gas line to the water heater.
- Check the gas lines and connections for leaks.
- Confirm that the gas inlet pressure is within limits.
- Confirm that the water heater is rated for the gas type supplied.
- Confirm that the electricity is supplied from 120 VAC, 60 Hz power source and is in a properly grounded circuit.
- Confirm that an extension cord or an adapter plug has **NOT** been used with the water heater.

CONTROLLER DIAGNOSTICS

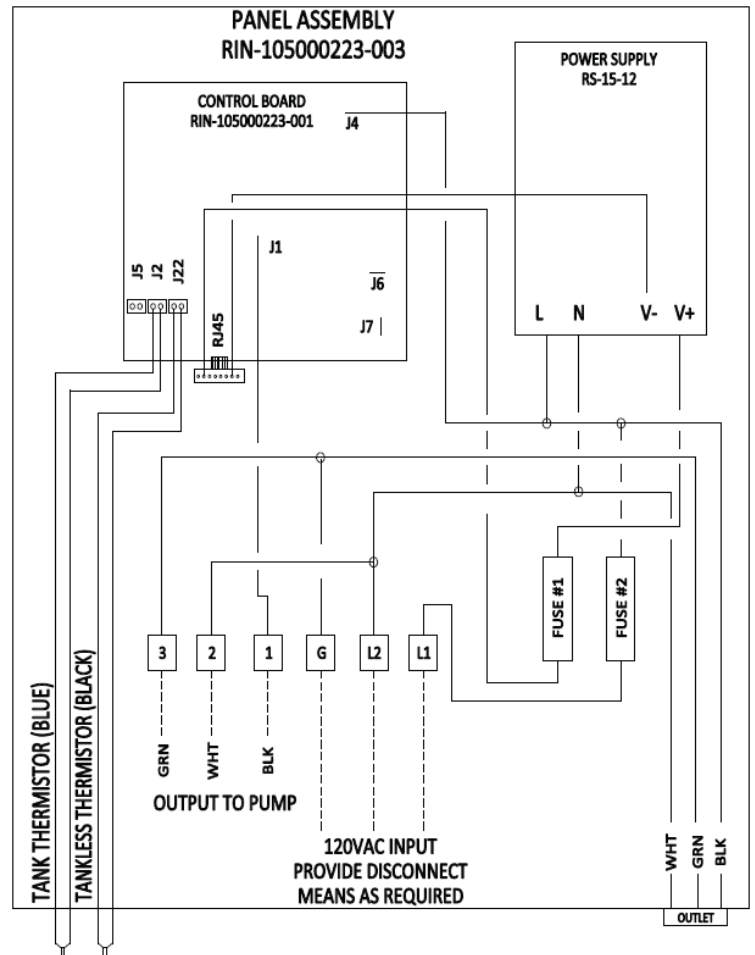
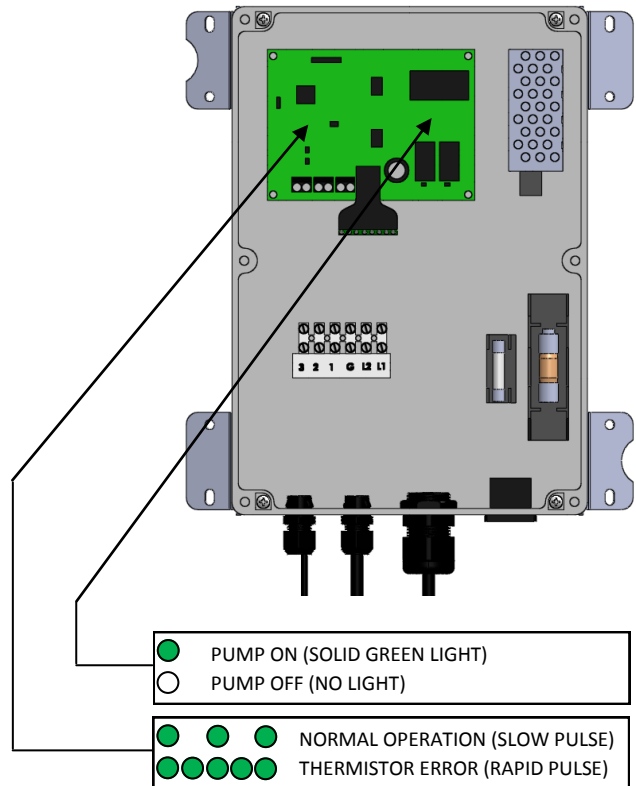

Condensate

Condensate can form in the vent of high efficiency direct vent appliances. Without proper drainage, condensate will damage the heat exchanger.

To prevent condensate damage, follow these instructions.

DO NOT

- Do not connect the condensate drain pipe directly to the rain sewer.
- Do not connect the condensate drain line with an air conditioning evaporator coil drain.
- Do not pipe condensate drain, temperature-pressure relief valve, and/or pressure relief valve together into a common pipe.

MUST DO

- Use only venting that is approved and identified as acceptable for your particular model.
- Slope the venting toward the appliance according to the vent manufacturer's installation instructions.
- All condensate must drain and be disposed of according to local codes.
- Use only corrosion resistant materials for the condensate drain lines such as PVC pipe or plastic hose.
- The condensate drain pipe (along its entire length) must be at least the same diameter as the drain line, (1/2 inch NPT).
- The end of the condensate drain pipe should be open to the atmosphere. The end should not be under water or other substances.
- To minimize freezing of the condensate, run the condensate drain line through an interior wall or between insulation and an interior wall.
- Ensure that condensate drain, PRV, and T & P are piped separately to their own dedicated drain lines.

INFORMATION

- Water heaters have an integrated condensate collector.
- The condensate drain pipe should be as short as possible and have a downward pitch.
- If the condensate drain gets blocked, a diagnostic code will display on the controller. If this occurs, the condensate drain must be cleaned.
- The condensate trap will automatically prime (self-prime) during operation of the unit as condensate forms. Condensate draining from the unit indicates that the trap is full and that there is no blockage in the condensate drain. It is not necessary to add water to the condensate trap.
- A condensate neutralizer kit, 804000074, is available from Rinnai. The kit allows condensate to flow through neutralizing media that raises the pH of the condensate to a level that will help prevent corrosion of the drain and public sewer system.

Checklist for Venting and Condensate

- Verify proper clearances around the vents and air intakes.
- Ensure you have used the correct venting products for the model installed and that you have completely followed the venting manufacturer's installation instructions and these installation instructions.
- Verify that the vent system does not exceed the maximum length for the number of elbows used.

A Condensate line must be installed to the 1/2" MNPT connection located at the bottom of the tankless unit. The condensate line must be routed out of the system enclose with a downward pitch

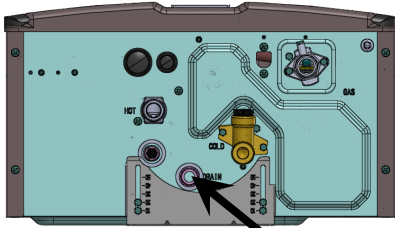

**Condensate Connection
(1/2" MNPT)**

Following are two examples on how to rout the condensate line.

1. Cut a hole in the lower enclosure that will maintain appropriate pitch of the condensate line.

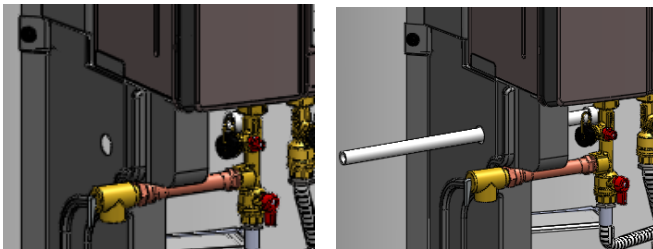

2. Route the condensate line out through the opening locate at the base of the lower enclosure.

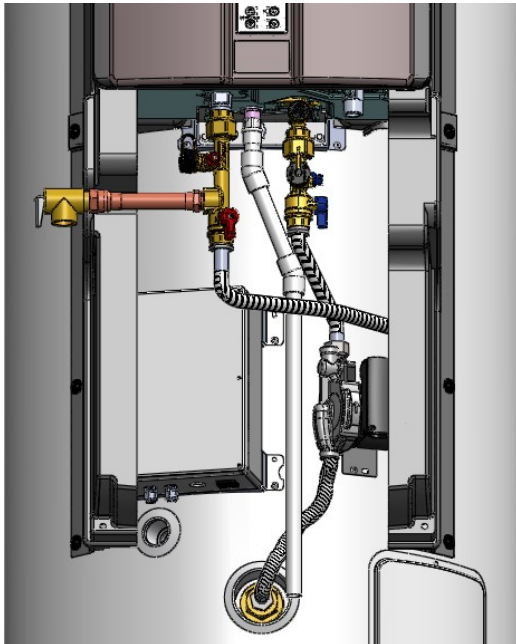

3. Reinstall the lower enclosure using the plastic rivet screws to secure it into place.



Final Checklist

- The water heater is not subject to corrosive compounds in the air.
- The water supply does not contain chemicals or exceed total hardness that will damage the heat exchanger.
- Clearances from the water heater unit are met.
- Clearances from the vent termination / air intake are met.
- Ensure you have used the correct venting products for the model installed and that you have completely followed the venting manufacturer's installation instructions and these installation instructions.
- Verify that the vent system does not exceed the maximum length for the number of elbows used.
- Verify that SW 1 in DIPSW 1 has been adjusted for vent length if necessary. Refer to the section on Maximum Vent Length.
- Purge the water line of all debris and air by closing the hot isolation valve and opening the cold isolation valve and its drain. **Debris will damage the water heater.** Use a bucket or hose if necessary.
- Ensure that hot and cold water lines are not crossed to the unit and are leak free.
- A manual gas control valve has been placed in the gas line to the water heater.
- Ensure that a pressure relief valve is installed with a rating that exceeds the BTU input of the water heater model. Refer to the rating plate on the side of the water heater for BTU input.
- Clean the inlet water filter by closing the cold and hot water inlet isolation (shut-off) valves. Put a bucket under the filter at the bottom of the water heater to catch any water that is contained inside the unit. Unscrew the water filter. Rinse the filter to remove any debris. Install the filter and open the isolation valves.
- Check the gas lines and connections for leaks.
- Confirm that the gas inlet pressure is within limits.
- Confirm that the water heater is rated for the gas type supplied.
- Confirm that the electricity is supplied from a 120 VAC, 60 Hz power source, is in a properly grounded circuit, and turned on.
- Verify the temperature controller is functioning properly.
- Verify that SW 2 and SW 3 in DIPSW 1 is set correctly for your altitude.
- Verify the system is functioning correctly by connecting your manometer to the gas pressure test port on the water heater. Operate all gas appliances in the home or facility at high fire. The inlet gas pressure at the water heater must not drop below that listed on the rating plate.
- DO NOT** introduce toxic chemicals such as those used for boiler water treatment to the potable water used for space heating.
- If the water heater is not needed for immediate use, then drain the water from the heat exchanger.
- Install the front panel.
- Explain to the customer the importance of not blocking the vent termination or air intake.
- Explain to the customer the operation of the water heater, safety guidelines, maintenance, and warranty.
- The installation must conform with local codes or, in the absence of local codes, with the *National Fuel Gas Code, ANSI Z223.1/NFPA 54*, or the *Natural Gas and Propane Installation Code, CSA B149.1*.
- Leave this manual and the entire RUC98I manual taped to the water heater, or give both manuals directly to the consumer.**

Technical Data

Specifications		
Minimum Gas Consumption Btu/h (kW/h)	15,200 (4.5)	
Maximum Gas Consumption Btu/h (kW/h)	199,000 (58.3)	
Tank Volume	119 Gallons (450 Liters)	
First Hour Delivery	315 Gallons (1192 Liters)	
Temperature Setting	98° – 120° F (37° – 49° C) (factory default). Maximum temperature is selectable at 120° F (49° C) or at 140° F (60° C).	
Product Weight	428 lb (194 kg)	
Noise level	52 dB	
System Electrical Data	Normal	256 W
	Standby	44 W
	Anti-frost Protection	326 W
	Max Current	5.5 A
	Fuse	Tankless Engine - 10 A, Controller - 10 A
By-Pass Control	Electronic	
Gas Supply Pressure	Natural Gas	4.0 - 10.5 inch W.C.
	Propane	8.0 - 13.5 inch W.C.
Appliance Type	Condensing Hybrid System: Condensing tankless, Insulated Storage Tank, Pump & Control	
Connections	Gas Supply Inlet - 3/4" MNPT Hot Water Outlet - 2" MNPT Cold Water Inlet - 2" MNPT	
Ignition System	Direct Electronic Ignition	
Electric Connections	Appliance: AC 120 Volts, 60Hz. Integrated Temperature Controller: DC 12 Volts (Digital)	
Water Temperature Control	Simulation Feed forward and Feedback	
Maximum Water Supply Pressure	150 PSI	
Residential Energy Star Certified (RUC98i)	Yes	
Complies with South Coast Air Quality Management District 14 ng/J or 20 ppm NOx emission levels (RUC98i)	Yes	

RECOVERY CAPACITIES

Gas Type	Input		U.S. GALLON/HR LITERS/HR AT TEMPERATURE RISE INDICATED													
			Tank Capacity	°F	30°F	40°F	50°F	60°F	70°F	80°F	90°	100°F	110°F	120°F	130°F	140°F
	BTU/HR	kW		°C	17°C	22°C	28°C	33°C	39°C	44°C	50°C	56°C	61°C	67°C	72°C	78°C
NAT/ LP	199,000	58	119 U.S. Gals.	GPH	772	579	463	386	331	289	257	232	211	193	178	165
			450 Liters	LPH	2922	2192	1753	1461	1253	1093	973	878	799	731	673	625

* First Hour Delivery Rating is a theoretical calculation based on 70% usable tank capacity (tank capacity x .70 + (recovery) = First Hour Rating)

Rinnai products are continually being updated and improved; therefore, specifications are subject to change without prior notice. The maximum inlet gas pressure must not exceed the value specified by the manufacturer. The minimum value listed is for the purpose of input adjustment.

Dimensions

Inches (millimeters)

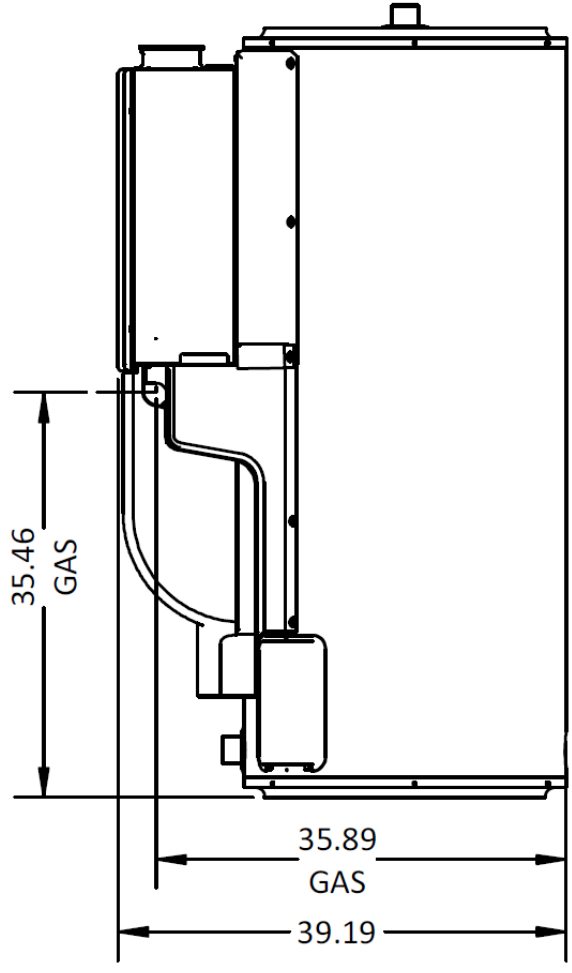
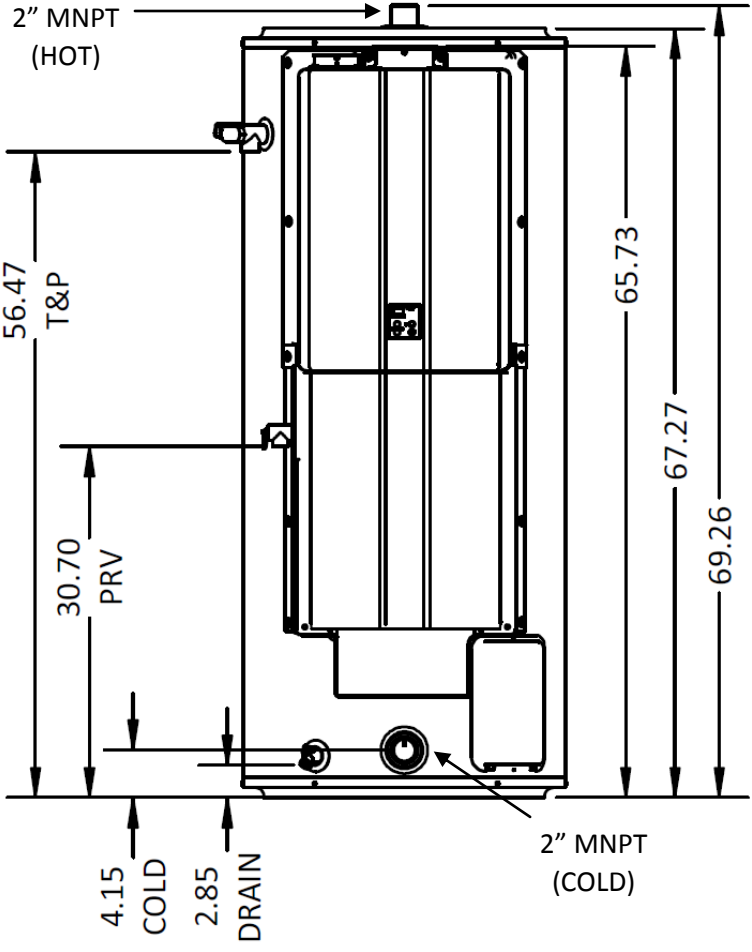
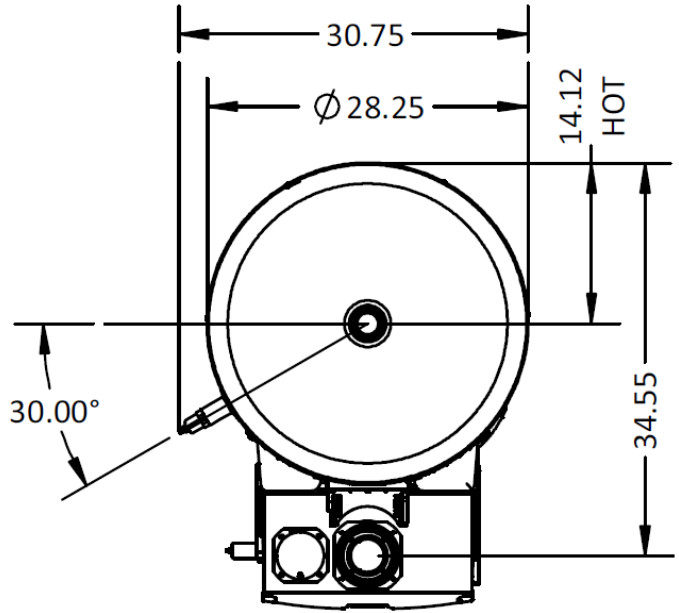

Storage Tank Maintenance

Anodes

The storage tank is equipped with two magnesium anodes designed to extend the life of the storage tank. Slowly consumed over time, the anode protects the glass-lined tank from corrosion. It is strongly recommended to inspect the anodes every two (2) years. If more than half of the anodes has been consumed, they should be replaced. Instructions on how to change the anodes can be obtained from the manufacturer.

The longevity of the storage tank can be reduced when a water softener is introduced to fight hard water. Sodium salts added by a softener can make the water extremely conductive; therefore, the anodes are consumed at a faster rate. In such conditions, the anodes should be inspected on a yearly basis.

In certain conditions, the anodes may react with the water, producing discolored or smelly water. The most common complaint is hot water that smells like rotten eggs. This is the result of the reaction between the anode and hydrogen sulphide gas dissolved in the water, which is common in well systems. This issue can usually be eliminated or reduced by changing the magnesium anodes to aluminum anodes and by chlorinating the storage tank and plumbing system. If the problem continues, special filtration equipment may be required. Under no circumstances are the anodes to be removed from the water heater on a permanent basis.

Removal of the anodes will lead to premature failure of the water heater and will void the warranty.

Storage Tank

Drain a pail of water through the drain valve at least once a year. This will remove excess sediment from the bottom of the tank. This sediment, if allowed to accumulate, will reduce the efficiency and the life of the tank.

Draining the Storage Tank

To completely drain the storage tank:

1. Turn the power "OFF" to the system by unplugging power to the system. (The system will not be fully shut down by simply pressing the power button on the controller)
2. Close the cold water supply manual shut-off valve.
3. Connect one end of a garden hose to the storage tank drain valve and put the other end next to a free-flowing drain.
4. Open the drain valve by turning the knob counter clockwise ↺
5. Open a hot water faucet to allow air into the system.

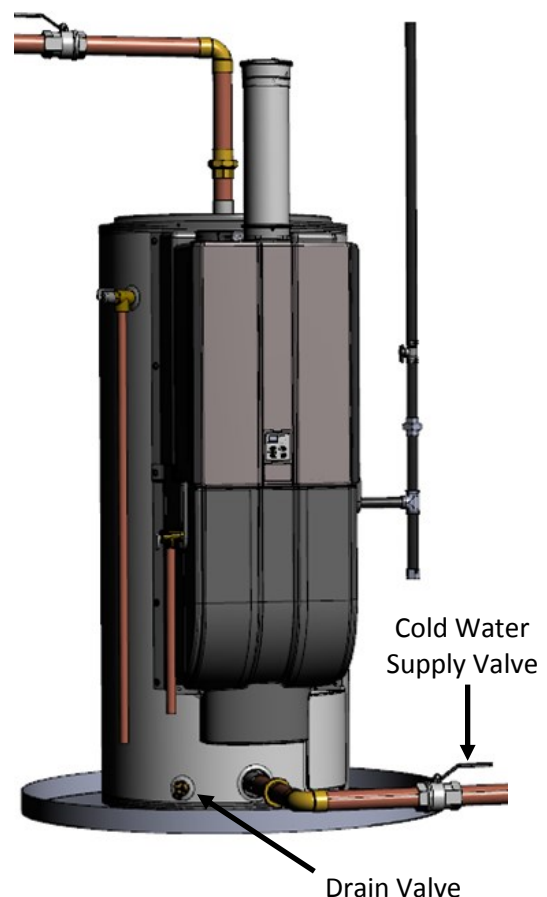

REPLACEMENT PARTS

ITEM NO.	PART NUMBER	DESCRIPTION
1	RUC98i	TANKLESS RUC98i
2	109000519	TOP LEFT COVER
3	109000518	TOP RIGHT COVER
4	109000521	LOWER LEFT COVER
5	109000520	LOWER RIGHT COVER
6	109000517	FRONT COVER
7	107000180	2 IN DIELECTRIC NIPPLE
8	107000181	1 IN DIELECTRIC NIPPLE
9	107000157	T&P RELIEF VALVE (FVMX-5C)
10	WRIK-LF-F	VALVE KIT (COLD, HOT, PRV)
11	107000162	PRV PIPE
12	105000229	CONTROLLER ASSEMBLY
13	105000225	THERMISTOR, 3/4MNPT, 10K Ohm
14	105000223	CLIP ON THERMISTOR, 10K Ohm
15	107000182	HEX REDUCING BUSHING, 2IN MALE X 3/4 FEMALE
16	107000161	PUMP
17	107000183	TANK CLEANOUT FLANGE GASKET
18	107000184	HAND HOLE CLEANOUT COVER
19	109000552	CLEANOUT BOLTS 5/16IN-18 X 1IN
20	107000160	FLEX, LENGTH 7.80IN, 3/4 NPSH X 3/4 MNPT
21	107000158	FLEX, 18 X 3/4 NPSH X 3/4 MNPT
22	107000164	TUBE, 26-1/4 X 3/4 NPSH X 3/4 MNPT
23	107000185	90° FEM X MALE ELBOW, 3/4IN
24	107000186	HEX NIPPLE, 3/4 IN
25	107000187	HEX REDUCING BUSHING, 1 IN MALE X 3/4 FEMALE
26	107000155	TANK, 119 GALLON W/ BRACKETS
27	107000188	ANODE ROD, MAGNESIUM
28	107000189	BRASS DRAIN VALVE 3/4 X 2-3/4

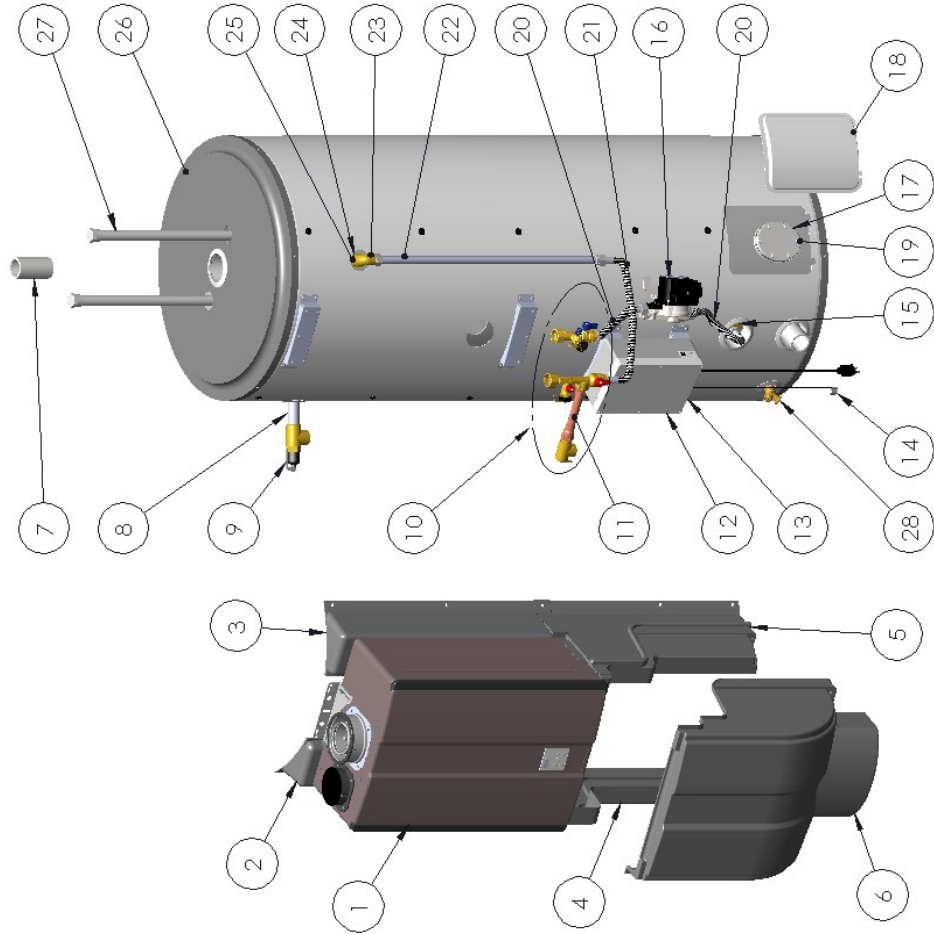

Limited Warranty for Ultra Series RUC98i

What is covered?

The Rinnai Standard Limited Warranty covers any defects in materials or workmanship when the product is installed and operated according to Rinnai written installation instructions, subject to the terms within this Limited Warranty document. This Limited Warranty applies only to products that are installed correctly United States and Canada. Improper installation may void this Limited Warranty. In order for this warranty to apply, it is required that you use a licensed professional who has attended a Rinnai installation training class before installing this water heater. This Limited Warranty coverage as set out in the table below extends to the original purchaser and subsequent owners, but only while the product remains at the site of the original installation. This Limited Warranty only extends to the first / original installation of the product and terminates if the product is moved or reinstalled at a new location

How long does warranty coverage last?

Item	Period of Coverage (from date of purchase)
	Residential Applications
Heat Exchanger	12 years [1] [2]
Storage Tank	6 years [1] [2]
All Other Parts and Components	5 years [1]

- [1] Period of coverage is reduced to 3 years from date of purchase when used as a recirculating water heater within a hot water recirculation loop, where the water heater is in series with a recirculation system and all recirculating water flows through the water heater, and where an aquastat / thermostat, timer, or an on-demand recirculation system is not incorporated.
- [2] The Rinnai Limited Warranty for a heat exchanger used in a recirculation system which is controlled through an aquastat/thermostat, timer, or an on-demand system is 12 years for residential applications and 5 years for commercial applications.
- [3] Labor coverage is extended to 5 years in residential applications and to 2 years in commercial applications if the product is registered within 30 days (except registration is not required in California and Quebec) and/or if the other conditions above in the Residential Applications and Commercial Applications sections are satisfied.

NOTE: The integrated controller on indoor models has a 1 year warranty on parts.

What will Rinnai do?

Rinnai will repair or replace the covered product or any part or component that is defective in materials or workmanship as set forth in the above table. Rinnai will pay reasonable labor charges associated with the repair or replacement of any such part or component during the term of the labor warranty period. All repair parts must be genuine Rinnai parts. All repairs or replacements must be performed by a licensed professional that is properly trained, state qualified or licensed to do the type of repair.

Replacement of the product may be authorized by Rinnai only at its sole discretion. Rinnai does not authorize any person or company to assume for it any obligation or liability in connection with the replacement of the product. If Rinnai determines that repair of a product is not possible, Rinnai may replace the product with a comparable product at Rinnai's sole discretion. The warranty claim for product parts and labor may be denied if a component or product returned to Rinnai is found to be free of defects in material or workmanship; damaged by improper installation, use or operation; or damaged during return shipping.

How do I get service?

You must contact a licensed professional for the repair of a product under this Limited Warranty. For the name of a licensed professional please contact your place of purchase, visit the Rinnai website (www.rinnai.us), call Rinnai at 1-800-621-9419 or write to Rinnai at 103 International Drive, Peachtree City, Georgia 30269.

Proof of purchase is required to obtain warranty service. You may show proof of purchase with a dated sales receipt, or by *registering within 30 days of purchasing the product*. To register your tankless water heater, please visit www.rinnai.us. For those without internet access, please call 1-866-RINNAI1 (746-6241). Receipt of Registration by Rinnai will constitute proof-of-purchase for this product. Registration of product installed in new home construction may be verified with a copy of the closing papers provided by the initial home buyer. However, Registration is not necessary in order to validate this Limited Warranty.

What is not covered?

This Limited Warranty does not cover any failures or operating difficulties due to the following:

- accident, abuse, or misuse
- alteration of the product or any component part
- misapplication of this product
- improper installation (such as but not limited to)
 - ◇ product being installed in a corrosive environment
 - ◇ condensate damage
 - ◇ improper venting
 - ◇ incorrect gas type
 - ◇ incorrect gas or water pressure
 - ◇ absence of a drain pan under the appliance
- improper maintenance (such as but not limited to
 - scale build-up, freeze damage, or vent blockage)
 - incorrect sizing
 - any other cause not due to defects in materials or workmanship
 - problems or damage due to fires, flooding, electrical surges, freezing or any acts of God.
 - any damage caused by poor water quality
 - operating the water heater with anything other than potable water at all times
 - force majeure

There is no warranty coverage on product installed in a closed loop application, commonly associated with space heating only applications.

This Limited Warranty does not apply to any product whose serial number or manufacture date has been defaced.

This Limited Warranty does not cover any product used in an application that uses chemically treated water such as a pool or spa heater.

Limitation on Warranties

No one is authorized to make any other warranties on behalf of Rinnai America Corporation. Except as expressly provided herein, there are no other warranties, expressed or implied, including, but not limited to warranties of merchantability or fitness for a particular purpose, which extend beyond the description of the warranty herein.

Any implied warranties of merchantability and fitness arising under state law are limited in duration to the period of coverage provided by this Limited Warranty, unless the period provided by state law is less. Some states do not allow limitations on how long an implied Limited Warranty lasts, so the above limitation may not apply to you.

Rinnai shall not be liable for indirect, incidental, special, consequential or other similar damages that may arise, including lost profits, damage to person or property, loss of use, inconvenience, or liability arising from improper installation, service or use. Some states do not allow the exclusion or limitation of incidental or consequential damages, so the above limitation may not apply to you.

This Limited Warranty gives you specific legal rights, and you may also have other rights which vary from state to state.

www.rinnai.us/warranty

EXTEND THE LABOR COVERAGE UNDER YOUR LIMITED WARRANTY*

Ultra Series RUC98i

REGISTRATION REQUIRED*

Rinnai is providing the opportunity to extend your Rinnai Standard Limited Warranty on labor only on Ultra Series models RUC98i. if you register within 30 days of purchase of your unit. Products not registered will still be covered under the Rinnai standard product limited warranty as provided in the Installation and Operation Instruction manual which comes with this product. Warranty information is also available on Rinnai's web site at www.rinnai.us.

RESIDENTIAL APPLICATIONS:

The limited warranty period on the labor coverage for models RUC80i, RUC90i, RUC98i, RU80e, RU90e and RU98e Tankless Water Heaters installed in a residential application is extended for an additional 48 months (a total of 60 months labor coverage from date of purchase), when used in a residential hot water application, if the product is registered within 30 days of purchase at www.rinnai.us/product-registration or by calling 1-866-RINNAI-1 (746-6241), except registration is not required in California and Quebec.

ADDITIONAL CONDITIONS OF EXTENDING THE LABOR COVERAGE UNDER THE LIMITED WARRANTY:

1. The labor coverage does NOT extend if the RUC98i Tankless Water Heater is used for structure heating or in a closed loop application.
2. If the product is installed on a circulation system, the circulation system must be controlled through an aquastat / thermostat, or timer, or an on-demand system, or the limited warranty will not be extended.

* **Only applicable if product is registered within 30 days of purchase and the other conditions are met. Note to California and Quebec Residents, and residents of other jurisdictions that prohibit warranty benefits conditioned on registration, registration is not required to obtain longer warranty periods and failure to register does not diminish your warranty rights. www.rinnai.us/warranty**

NOTES

A tradition of **TRUE RELIABILITY.**

For nearly 100 years, we at Rinnai have been fiercely committed to delivering nothing less than a superior experience at every touch point.

Beyond manufacturing the highest quality products, our people stand behind all that we make—before, during and long after installation. From the 24/7/365 technical support for professionals, to our national network of independent installers, to on-staff engineers who can assist with choosing the right products and sizes—we're inspiring confidence right along with the comfort our solutions provide.



Rinnai[®]

Learn more about Rinnai high-performance Tankless Water Heaters,
Hybrid Water Heating Systems, Boilers, Vent-Free Fan Convectors
and EnergySaver[®] Direct Vent Wall Furnaces at:

rinnai.us

Rinnai America Corporation • 103 International Drive, Peachtree City, GA 30269
1-800-621-9419 • rinnai.us

©2017 Rinnai America Corporation. Rinnai America Corporation continually updates materials, and as such, content is subject to change without notice. Local, state provincial, federal and national fuel gas codes must be adhered to prior to and upon installation.

100000446(02)
8/2017